

Installation Instructions for 2-1/16" Oil Temperature Gauge w/ 9204 Sending Unit

Before You Start

This gauge features peak recall, programmable high and low full dial warning and external warning output. Please read the instructions completely before installing.

- **ALWAYS WEAR SAFETY GLASSES.**
- Install the gauge only when the engine is cool and ignition is off.
- Make sure all necessary tools, materials, and parts are on hand.
- Disconnect the negative (-) battery cable before installing the gauge.
- 2-1/16" gauge mounts in a 2-1/16" diameter hole.
- Make sure the mounting location does not impair visibility or interfere with driving. Also check behind the mounting location for any wiring or components before drilling.

Fig 1. Wiring Diagram

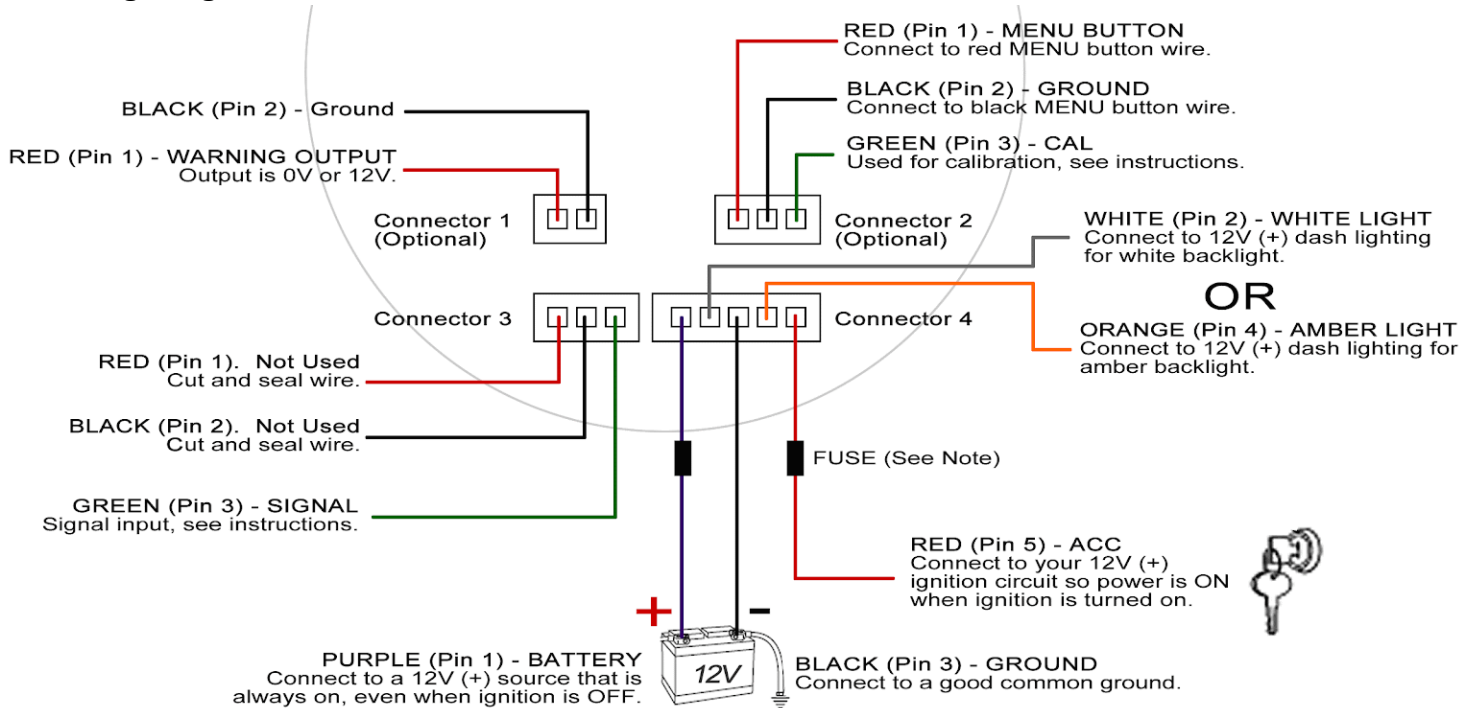

Wiring

Use 20 AWG stranded or heavier wire for installation. Route wires away from any moving parts and hot engine components. Secure wires firmly along their route. **Cut and seal all unused wire connections.**

Note: As a safety precaution, the RED (Pin 5) and PURPLE (Pin 1) 12V+ connections should be fused. We recommend using a 1 Amp, fast-acting type cartridge fuse.

MENU Button Installation

Installation of the remote MENU button is only necessary if you want to use the RECALL and WARNING features of the gauge

Mount the included MENU button in a location that is convenient. Connect the red wire from the button to Connector 2, Pin 1 (Red) and the black wire on the button to Connector 2, Pin 2 (Black). See Fig 1.

Temperature Signal Input

Connect the sender connection to one end of the included 22 Ohm resistor. Connect the other end of the resistor to the gauge signal input (Pin 3, Connector 3). Ensure the body of the sending unit is grounded.

Make sure the gauge sending unit body has a good common ground, i.e. ground the gauge and sending unit at the same location.

Use Teflon sealing compound on the sender threads.

Test temperature sender connection for leaks. If a leak is detected, determine the cause of the leak and repair. DO NOT operate the vehicle if a leak is detected.

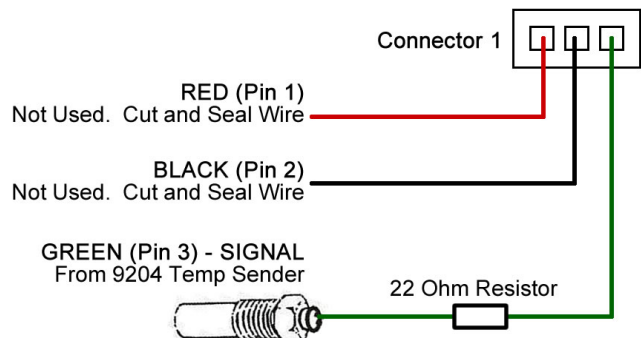

Programming Full Dial Low Warning (WARN LO)

This gauge can be configured to show a full dial low warning (flashing backlight) when the pointer goes below a specific value (i.e. 10V).

1. To access the WARN LO programming mode, press and hold the MENU button until the pointer moves to 25% scale (approx 1 second). Release the MENU button after the pointer has reached 25% scale.
2. After releasing the MENU button the pointer will move to the current low warning set point. Factory default is 0% scale (WARN LO deactivated).
3. To change the set point, press the MENU button repeatedly to move the pointer by 2% increments. Once the pointer reaches 100% scale, pressing the MENU button will decrease the pointer position by 2% increments.
4. Once the pointer indicates your desired low warning set point, leave the MENU button untouched for 5 seconds. The low warning set point will be saved and the gauge will return to normal operating mode.

To turn the low warning OFF, repeat steps 1-4 above and change the low warning set point to 0% or 2% scale. Setting the low warning set point to 0% or 2% deactivates the low warning feature.

Viewing and Clearing Peak Value (RECALL)

1. To view the peak value, press the MENU button one time.
2. To exit RECALL mode press the MENU button one time.
3. To clear the stored peak value, press and hold the MENU button for 3 seconds while in RECALL mode.

External Warning Output

This gauge features an external output that can be used to activate and deactivate warning lights or other vehicle systems such as fans, heaters, and pumps.

When a high or low warning condition exists the gauge outputs a 12V+ DC signal (500mA) on Pin 1 of Connector #1 (See Fig 1). The output is 0V when a high or low warning condition does not exist.

Do not install Connector 1 if external warning output is not required.

Programming Full Dial High Warning (WARN HI)

This gauge can be configured to show a full dial high warning (flashing backlight) when the pointer exceeds a specific value (i.e. 15V).

1. To access the WARN HI programming mode, press and hold the remote button until the pointer moves to 75% scale (approx 3 seconds). Note: the pointer will stop at 25% scale for approx 1 second (for WARN LO programming mode), continue holding the button until the pointer has reached 75% scale. Release the button after the pointer has reached 75% scale.
2. After releasing the button the pointer will move to the current high warning set point. Factory default is 100% scale (WARN HI deactivated).
3. To change the set point, press the MENU button repeatedly to move the pointer by 2% increments. Once the pointer reaches 0% scale, pressing the MENU button will increase the pointer position by 2% increments.
4. Once the pointer indicates your desired high warning set point, leave the MENU button untouched for 5 seconds. The high warning set point will be saved and the gauge will return to normal operating mode.

To turn the high warning OFF, repeat steps 1-4 above and change the high warning set point to 98% or 100% scale. Setting the high warning set point to 98% or 100% deactivates the high warning feature.

Full Dial Warning (WHITE/AMBER/OFF)

The full dial warning has three modes: WHITE, AMBER, and OFF. To change the full dial warning mode:

1. Press and hold the MENU button until the pointer moves to 100% scale (approx 4 seconds). Note: the pointer will stop at 25% scale for approx 1 second, then 75% for approx. 1 second. Do not release the MENU button until the pointer has reached 100% scale. Release the button after the pointer reaches 100% scale.
2. After releasing the button, the gauge backlighting will indicate the current Full Dial Warning mode as follows: WHITE (flashing white backlight), AMBER (flashing amber backlight) and OFF (no backlighting).
3. Press the MENU button briefly to switch the full dial warning mode. Continue pressing the MENU button briefly until the desired full dial warning mode is active.
4. To save your changes, leave the MENU button untouched for 5 seconds. Full Dial Warning Mode will be saved and the gauge will return to normal operating mode.